

Syntax

1

Bhupendra Nandlal Kesur
Department of English
M. J. College, Jalgaon

Topics to be covered

2

- Meaning and Nature of Syntax
- Parts of Sentence: Subject and Predicate
- Elements of Sentence: Subject, verb, object, complement and adverbial
- Sentence Structure: Deep and Surface Structure
- Sentence Analysis: Immediate Constituents in Tree Diagram.

Definition of Syntax

3

- Syntax is the study of the rules governing the way words are combined to form sentences in a language.
 - *garden the
 - *Children are
 - *Work in
- This class: *what syntactic structure is and what the rules that determine syntactic structure are like.*

Syntax

4

- Properties of syntactic knowledge:
 - *Humans can understand & produce an infinite number of sentences they never heard before*
 - ✦ “Some purple gnats are starting to tango on microwave”
 - *Our grammar can understand and produce long sentences*
 - ✦ “Bill said that he thought that the esteemed leader of the house had it in mind to tell the unfortunate vice president that the calls that he made from the office in the White House that he thought was private.....”
 - *Determine the grammatical relations in a sentence*
 - ✦ Mary hired Bill. Vs. Bill hired Mary

Syntax & meaning

5

- Non-sense sentences with clear syntax
 - ✦ Colorless green ideas sleep furiously.
 - ✦ A verb crumpled the milk.
 - ✦ I gave the question a scuba-diving egg.
 - ✦ *Furiously sleep ideas green colorless.
 - ✦ *Milk the crumpled
 - ✦ *the question I an egg scuba-diving gave.
- Sentences are composed of discrete units that are combined by rules. These rules explain how speakers can store infinite knowledge in a finite space- brain.

Parts of a Sentence



A sentence is...



- A group of words with a **subject** and **verb** that expresses a complete thought.

SUBJECT PREDICATE

← The dog barked at the mailman. →

Sentence Fragments



- A **sentence fragment** is a group of words that looks like a sentence but...
 - does not contain both a subject and a verb OR
 - does not express a complete thought.

F / S When I get home

F / S Ran as fast as humanly possible

F / S Several decided not to attend

F / S Studied every spare moment

F / S As soon as we arrived

Write a sentence about this picture.
Draw a line between the *subject* and *predicate*



SUBJECT



- *The (complete) **subject** is the part of a sentence about which something is being said.*
 - It tells WHAT or WHOM the sentence is about.
 - It DOES something or is TALKED ABOUT.
1. A line of people | waited to see the movie.
 2. Standing in line were | several sailors.
 3. The day of the performance arrived.
 4. Because he had the hic-ups, he was asked to leave the library.

Simple Subject



- *The **simple subject** is the main word in the complete subject.*
1. My **date** for the dance | arrived late.
 2. The long trip across the desert | was over.
 3. She | was chosen congresswoman.
 4. A tense excitement filled the air.

Write a sentence about this picture.

Draw a line under the **complete subject** and a circle around the **simple subject**.



Compound Subjects



- *When two or more subjects have the same verb, it is called a **compound subject**.*
 - *Usually joined by “and” or “or”*
1. Alicia, Joy, and Carmen carried their books.
 2. Either New York or Los Angeles is our destination.
 3. English and science are exciting classes.
 4. After smelling smoke, the players and their fans were evacuated.

Write a sentence about the picture. Use a **compound subject** and underline it.



PREDICATE



- *The **predicate** is the part that says something about the subject. It contains the **VERB**.*
1. S.E. Hinton | wrote several books.
 2. The movie star | signed autographs for hours.
 3. Tuppie, a sweet dog, took a walk outside today.

Simple Predicate



- *The **simple predicate** is the VERB, or the main word or group of words in the predicate.*
- 1. The trees | **sagged** beneath the weight of the ice.
- 2. *Little Women* | **was written by** Louisa May Alcott.
- 3. After the concert, the guitarist | **will sign** autographs.
- 4. The small village is located near the river.

Compound Verbs



- Two or more connected verbs that have the same subject are called **compound verbs**.
1. The students **wrote** stories and **read** them aloud.
 2. The man **was convicted** but later **was found innocent**.
 1. You can **have a snack now** or **eat it later**.
 1. The student **remembered to study** but **forgot her homework**.

COMPLEMENTS



Words that complete the meaning of a verb are called *complements*.

1. I have a **test** today.
2. The sun feels **hot** on my shoulders.
3. You can buy **me dinner**.

DIRECT OBJECT



- The *direct object* receives the action expressed by the verb or names the result of the action.
- *Answers the question WHAT or WHOM after the verb*

SUBJECT

VERB

D.O.

1. **Volunteers distributed food** at the shelter.

SUBJECT

VERB

D.O.

2. **We watched the performance.**

3. The researchers followed the birds' migration.

INDIRECT OBJECT



- The *indirect object* precedes the direct object and tells TO WHOM or FOR WHOM the action of the verb is done.
- *Found by asking the question TO WHOM or FOR WHOM after the direct object*

SUBJECT VERB I.O. D.O.

1. My **parents** **gave** **me** a **cake** for my birthday.

SUBJECT VERB I.O. D.O.

2. **He** **would** not **tell** **you** a **lie**.

3. She sent her mother some earrings.

Predicate Nouns



- A noun which follows a linking verb and explains or identifies the subject is called a *predicate noun*.
- Predicate nouns never appear in prepositional phrases.

SUBJECT

L. VERB

PREDICATE NOUN

1. Ms. Sterne is an English teacher.

SUBJECT

L. VERB

PREDICATE NOUN

2. Tuesday was my birthday.

3. He is one of the members.

Predicate Adjectives



- A word which follows a linking verb and describes or modifies the subject is called a *predicate adjective*.

SUBJECT L. VERB PREDICATE ADJ.

1. The ground looks swampy.

SUBJECT L. VERB PRED. ADJ.

2. These questions seem easy to me.

3. My dog is playful.

Common Linking Verbs



**BE: am, is, are, was, were,
be, being, been**

REMAIN

SOUND

FEEL

SMELL

LOOK

SEEM

BECOME

GROW

TASTE

What is the Main Verb?



- A main verb tells what the subject does or links the subject to another word that describes it.
- There are three types of verbs.
 - Action Verb
 - Linking Verb
 - Helping Verb

Action Verbs



- Action Verb—tells action subject performs.
 - The student strolled down the hall.
 - The teacher lectured for two hours.

Linking Verbs



- Linking Verb—connects subject to another word or words that describe it.
 - My math teacher is tall.
 - The college campus looks big.
 - Grammar seems difficult.

Helping Verbs



- Helping Verb—a helping verb joins the action verb to form the complete verb.
 - I should have studied more.
 - The teacher is lecturing.
 - He has been studying all day.

Interrupting Words



- Interrupting words may appear between verbs, but they are not part of the verb.
 - We did *not* go to the concert.
 - I have *often* observed students sleeping in the hallways.

Infinitives



- Infinitives are word phrases that begin with *to*.
 - To go
 - To walk
 - To speak
 - To write
- The main verb will never be an infinitive.
 - I wanted to go to the mall.

Correctly identifying the verb



- Ann teaches Philosophy.
(action verb)
- Ann is a teacher. (linking verb)
- Ann is teaching this summer.
(helping verb)

Generative Grammar

31

- Noam Chomsky 1950s
- *Generative* = a very explicit system of rules specifying what combinations of basic elements result in well-formed sentences.
- Defines the syntactic structure of a language.

Generative Grammar

32

- “all and only” = all grammatical sentences and only grammatical sentences
- Finite rules \rightarrow infinite number of well-formed sentences
- Productivity of language
 - Phrase structure rules
 - Transformational rules

Phrase structure rules

33

- Some words seem to belong together:
 - {The crazy man} {is jumping off the bridge}
- Groups of words that belong together are called **constituents**
- The component that determines the properties of the constituent is the **head**, and the constituent can be referred to as a **phrase**: e.g. **noun phrase**

Phrase Structure Rules

34

If we look at phrases, some patterns emerge:

Det N

- the instructor = NP

Det N

- a friend = NP

Det N

- some homework = NP

Det N

- two classes = NP

Phrase Structure Rules

35

Some more patterns:

V Det N

- call the instructor = VP

V Det N

- meet a friend = VP

V Det N

- do some homework = VP

V Det N

- skip two classes = VP

And yet more patterns:

Prep Det N

- with the instructor = PP

Prep Det N

- from a friend = PP

Prep Det N

- with some homework = PP

Prep Det N

- after two classes = PP

PSR

37

- Rules for determining the structure of phrases
- Generate a lot of sentences from a small number of rules.
- The structure of a phrase will consist of one or more constituents in a certain order.
- What does a NP consist of?
 - “noun phrases have a Det and a N”

NP Det N



Lexical Rules

38

- We need lexical rules to specify which words can be used when we rewrite constituents such as N.
 - PN {Mary, George}
 - N {girl, boy, dog}
 - Art
 - Pro →
 -

PSR

39

- V Det N V Det N V Det N
run a marathon eat the food read the book
- V Prep Det N V Prep Det N
go to the store talk with a teacher
- V Det N Prep Det N
take your sister to the library
- “Verb phrases have a V, (sometimes) an NP, and (sometimes) a PP”
- VP -> V (NP) (PP)

Syntax



Σ

Poor John ran away

VP – V + Adv
ran away

NP – Adj + N
Poor John



Poor John ran away

S {NP (Adj + N) + VP (V + Adv)}

The main phrase structure rules

42

1. $S \rightarrow NP VP$
2. $NP \rightarrow \{\text{Det } N, \text{Pro}, \text{PN}\}$
3. $VP \rightarrow V (NP) (PP) (\text{Adv})$
4. $PP \rightarrow P NP$
5. $AP \rightarrow A (PP)$

Phrase Structure Rules & tree diagrams

43

- NP \rightarrow (Det) N
- PP \rightarrow P NP

The boy (NP)

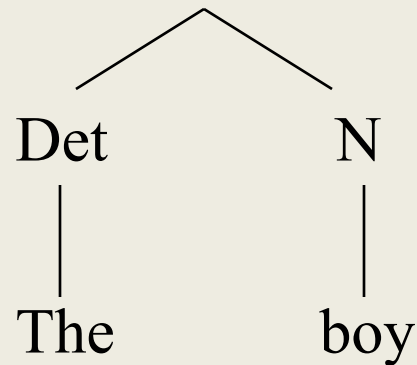

the boy in the yard

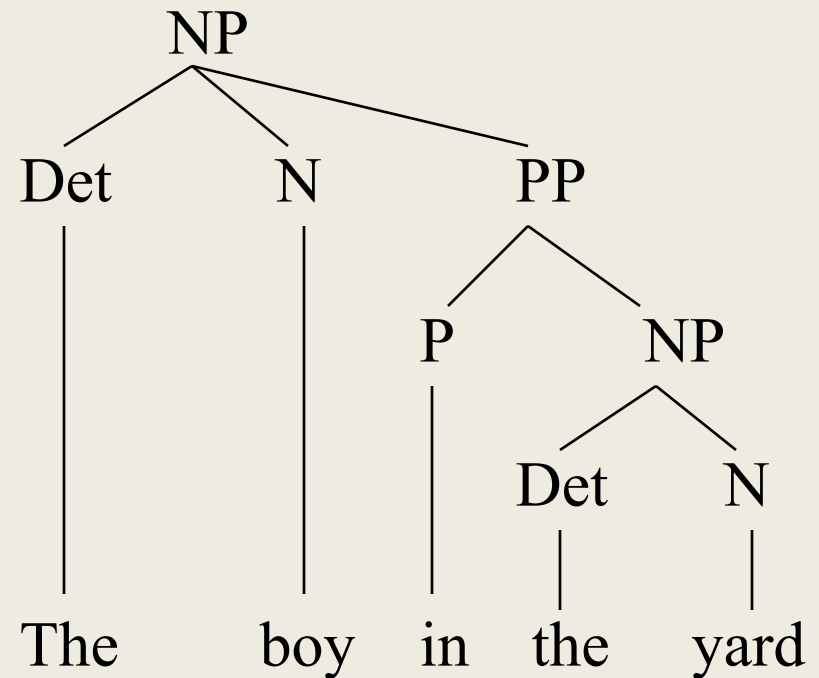

Phrase Structure Rules

44

- $VP \rightarrow V (NP) (PP)$
- $S \rightarrow NP VP$

took the money (VP)

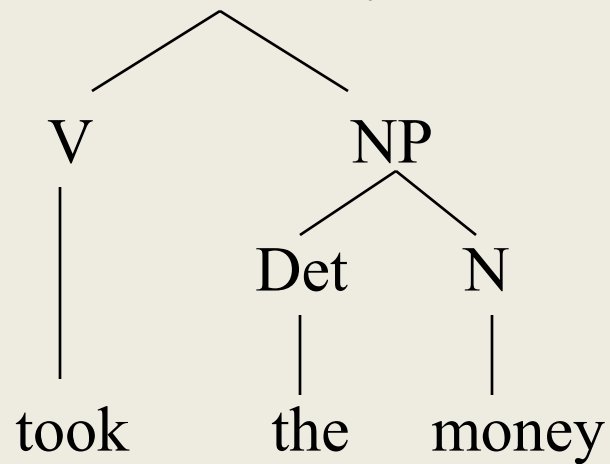

took the money from the bank

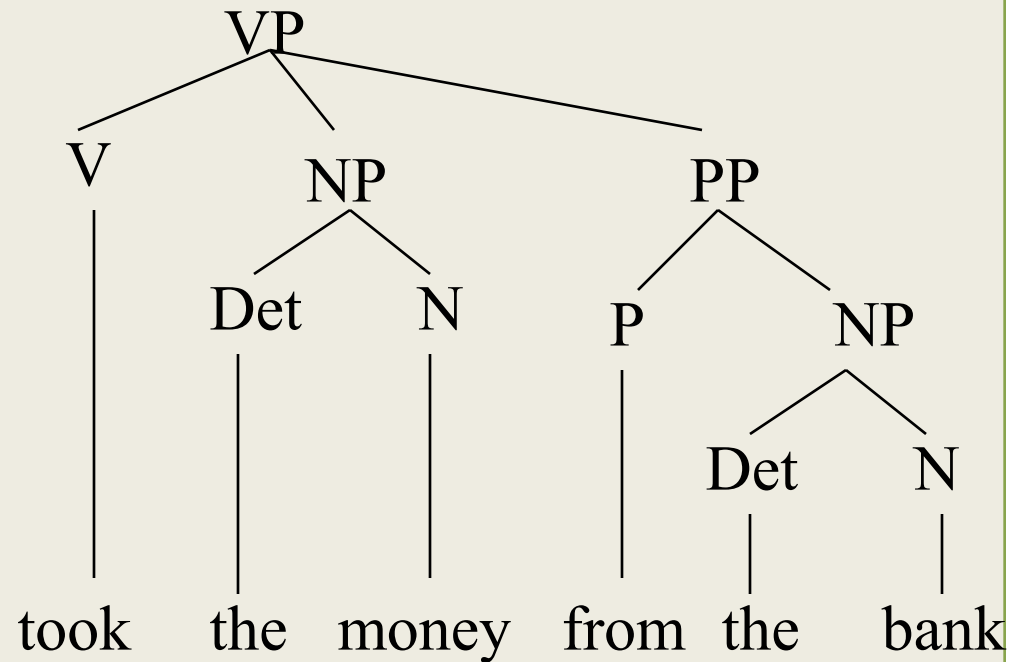

Example (1)

The old tree swayed in the wind

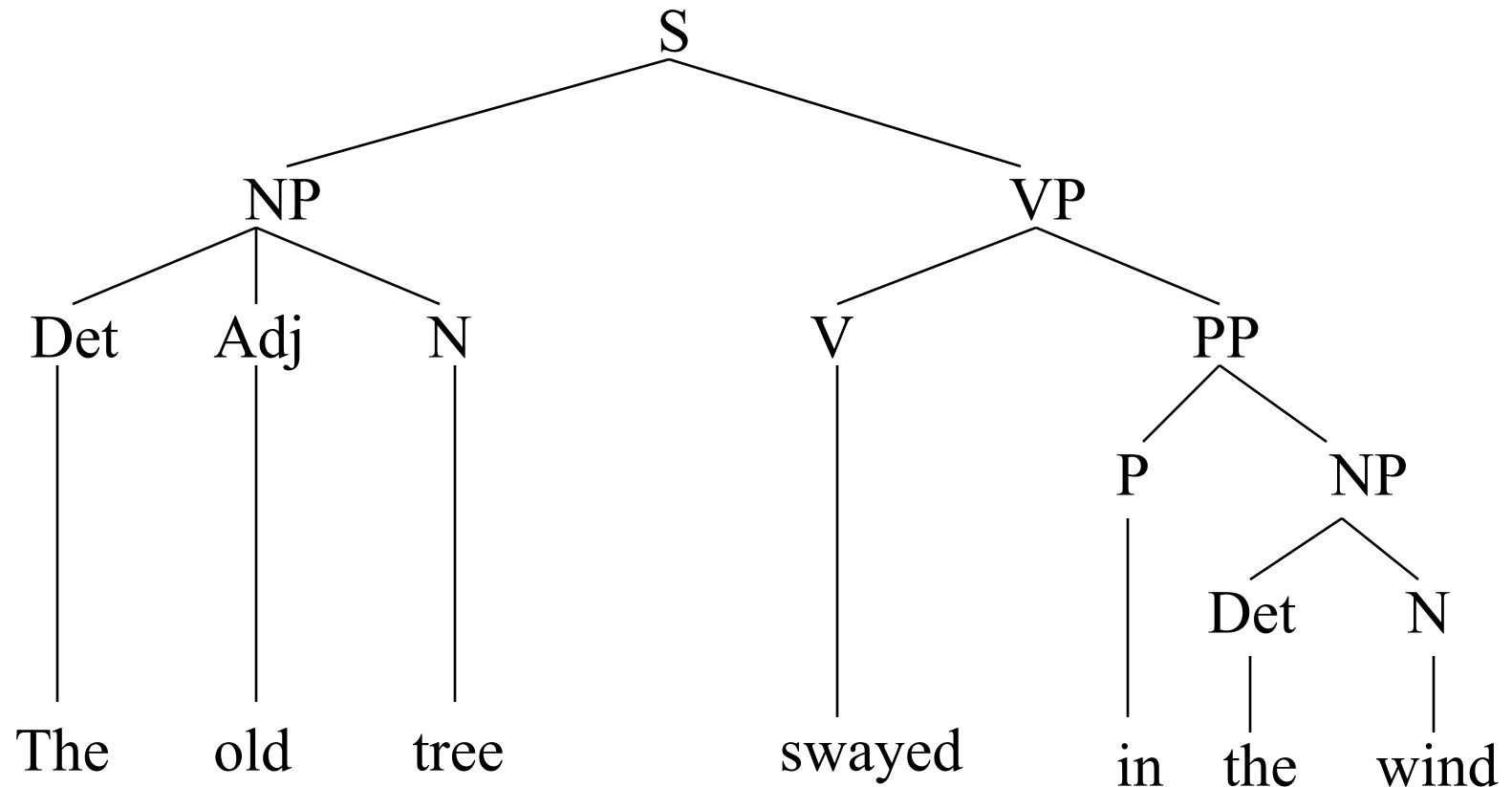

Example (2)

The children put the toy in the box

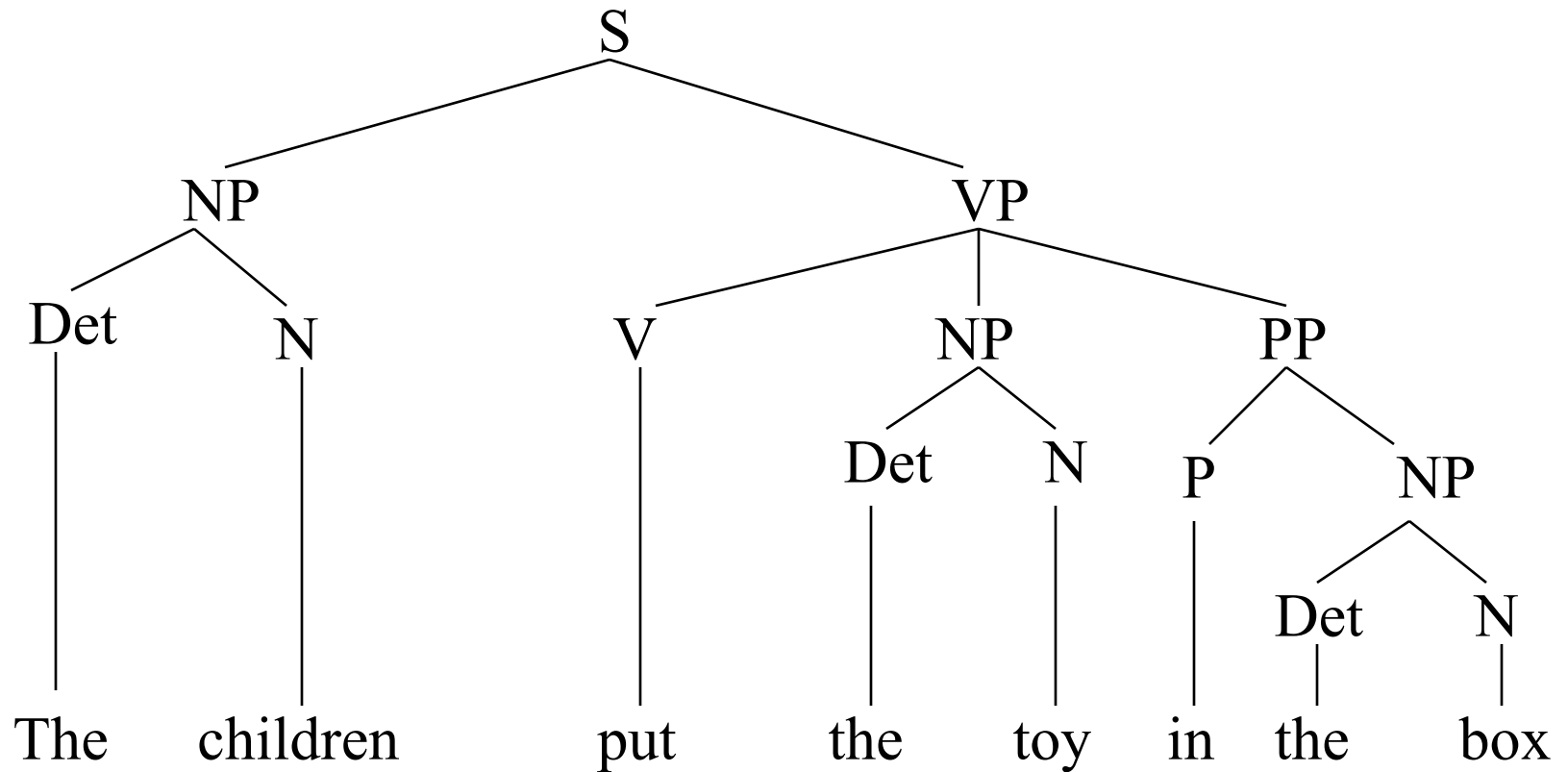

Example 3

47

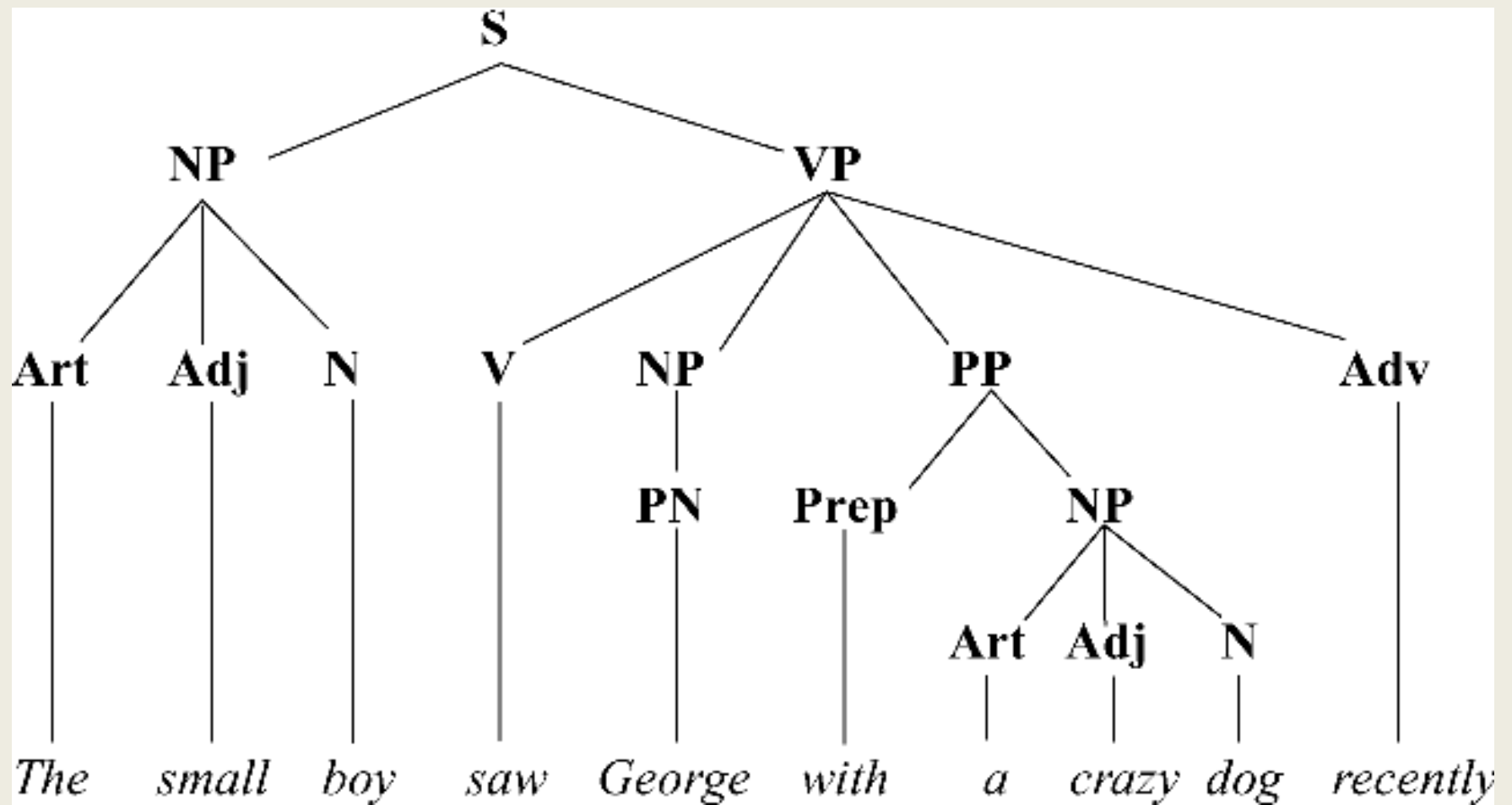

Deep and surface structure

48

- *The deep structure* is an abstract level of structural organization in which all the elements determining structural interpretation are represented.
 - Sentences that have alternative interpretations
 - Sentences that have different surface forms but have the same underlying meaning.
- *Surface structure*= how the sentence is actually represented

Deep and surface structure

49

- How superficially different sentences are closely related?
 - Charlie broke the window.
 - The window was broken by Charlie
 - Charlie who broke the window.
 - Was the window broken by Charlie?
- *Difference in their surface structure* = difference in syntactic forms
- *BUT they have the same 'deep' or underlying structure*

PS grammar

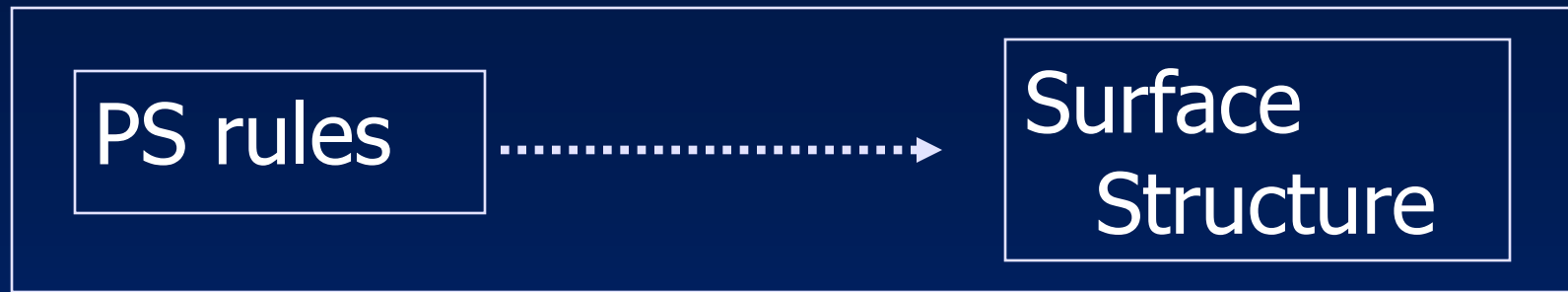

Transformational grammar

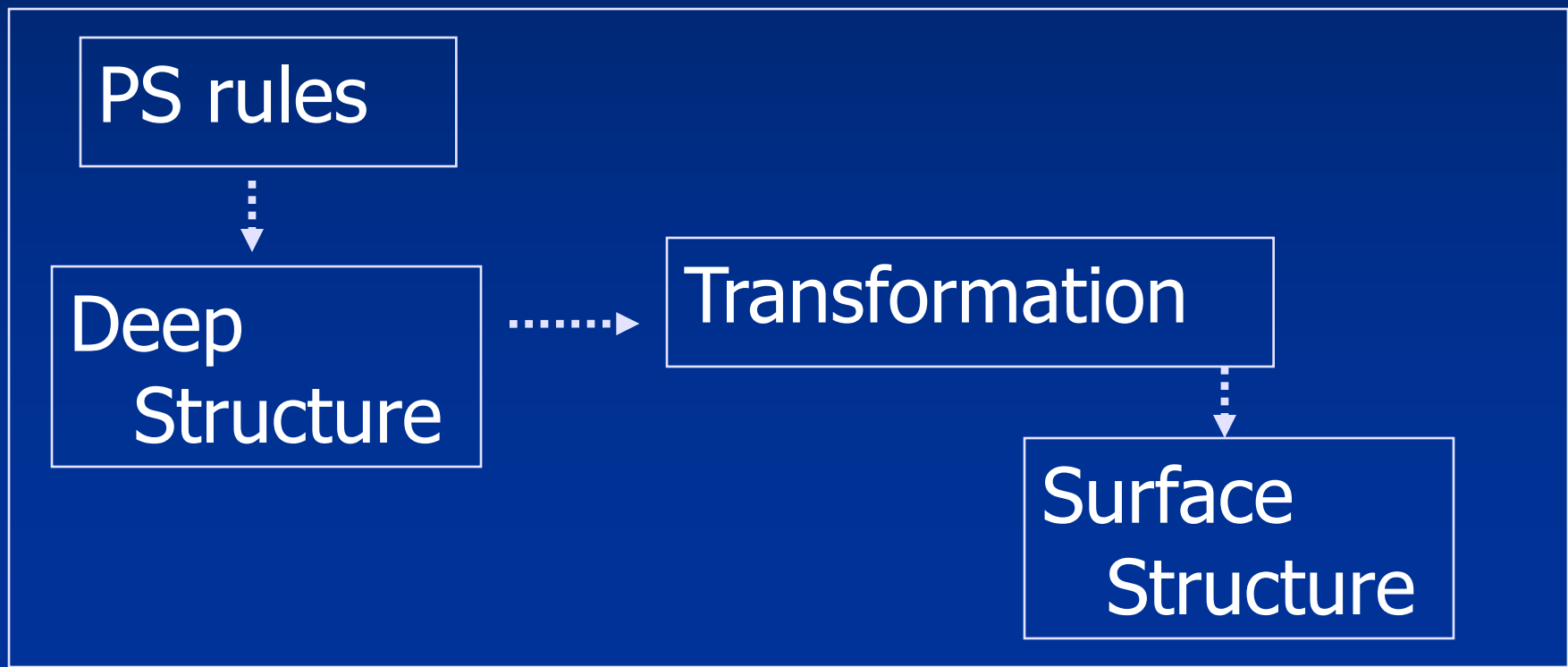

Structural ambiguity

51

- How superficially similar sentences are different?
(multiple meanings)
- E.g. *Annie whacked the man with an umbrella*
- *Same surface structure but different deep structure*
 - *The boy saw the man with a telescope*
- The question is: What is the scope of "with the telescope"? Does it modify only "the man" or does it modify "saw the man"?

Structural Ambiguity (1)

The boy saw the man with the telescope

52

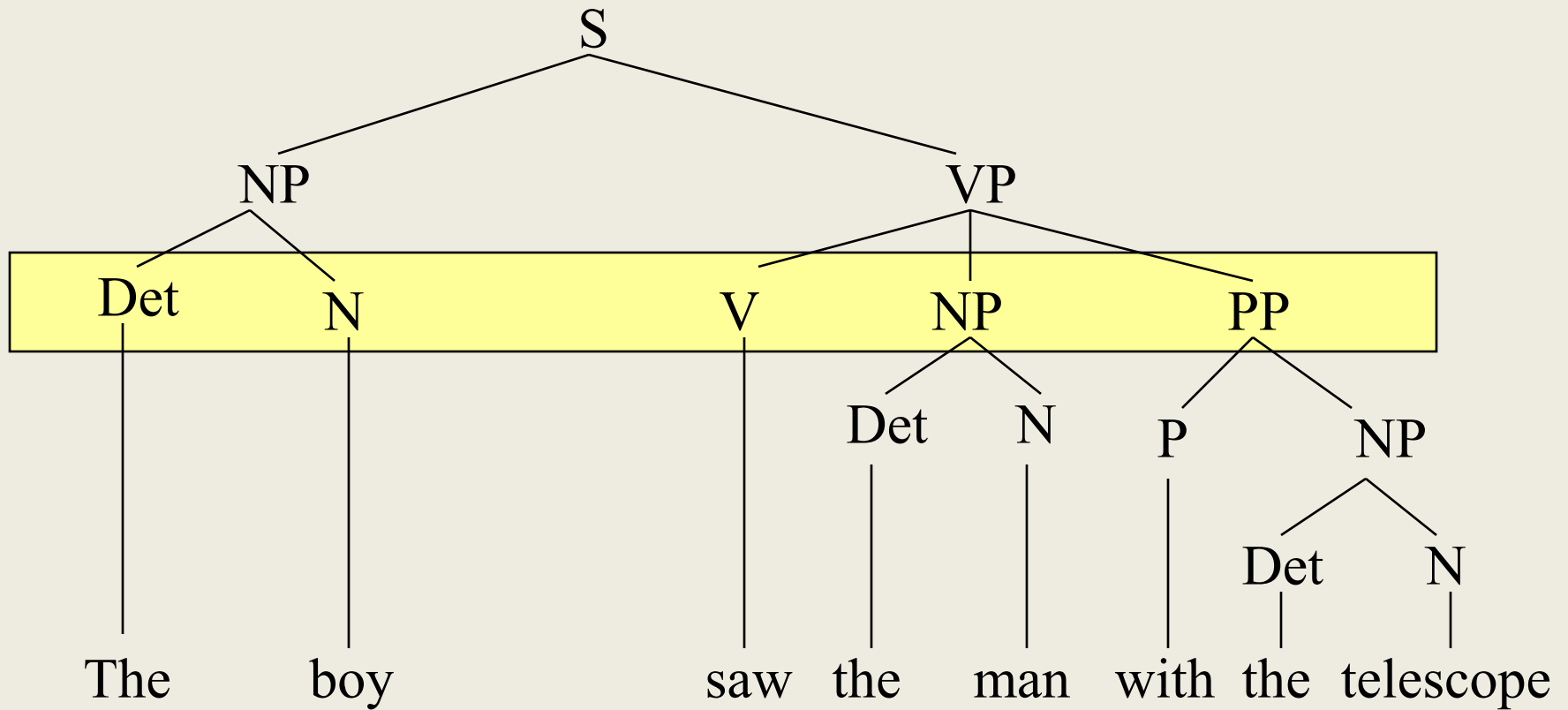

Meaning: Using the telescope, the boy saw the man

Structural Ambiguity (2)

The boy saw the man with the telescope

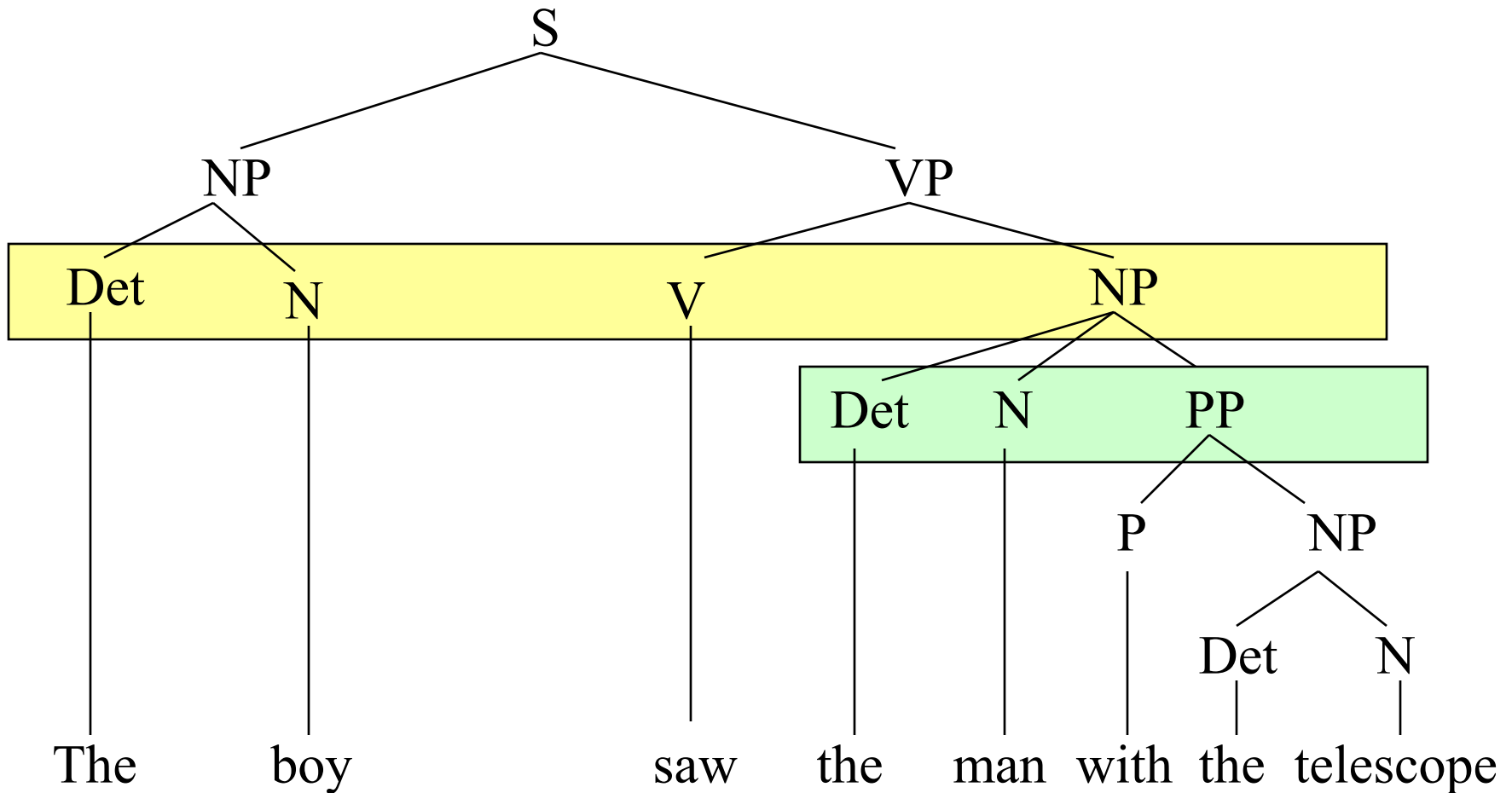

Meaning: The boy saw the man. The man had a telescope.

Recursion

54

- Rules can be applied more than once in generating sentences
- E.g. repeat prepositional phrase more than once
 - The gun was on the table near the window in the bedroom in the pink house
- Put sentences inside sentences
 - This is the cat *that* ate the rat *that* ate the cheese *that* was sold by the man *that* lived in the city *that* was on the river...
- No end to recursion- produce longer complex sentences

Back to recursion

55

- [Mary helped George]. (A sentence)
- [Cathy knew] that [Mary helped George].
(a sentence within a sentence)
- [John believed] that [Cathy knew] that [Mary helped George].
- The word *that* introduces the complement phrase

Complement Phrases

56

- Cathy knew *that* Mary helped George
- That = complementizer (C) introducing complement phrase (CP)
- The CP comes after the VP
- S NP VP →
- VP V CP →
- CP C S →

Transformational Rules

57

- Phrase structure rules represent ‘deep’ structure—always generate structures with fixed word order.
- *Mary saw George recently*
Recently Mary saw George
- Transformational rules= *take a specific part and attach it in another place*
- *You will help Cathy*
- *Will you help Cathy?*

Exercises

58

- Rewrite the following sentences with Phrase Structure Rules. Hint: Locate your principal NP and VP before beginning.
 - a) Miriam swims.
 - b) The dog is barking.
 - c) Peter told the truth.
 - d) The wicked witch spilled the potion.
 - e) The runner with the best time won the prize.

Exercises

59

- Draw a labeled tree diagram for the following English phrases.
- (Hint: what part of speech is the leader for the phrase?)
 - a. ancient pyramids
 - b. in the early evening
 - c. Drove a car

Exercises

60

- Draw phrase structure trees for the following sentences:
 - The puppy found the child
 - The ice melted
 - The hot sun melted the ice.
 - The house on the hill collapsed in the wind.
 - The boat sailed up the river.
 - A girl laughed at the monkey.

Exercises

61

- Draw two phrase structure trees representing the two meanings of the sentence:
 - *The magician touched the child with the wand.*

Exercises

62

- In what way these sentences are ambiguous?
 - We met an English history teacher
 - Flying planes can be dangerous
 - The parents of the bride and groom were waiting outside
 - The students complained to everyone that they couldn't understand.

Subjects & Predicates



Every complete sentence contains two parts: a **subject** and a **predicate**.

The **subject** is what (or whom) the sentence is about, while the **predicate** tells something about the subject.

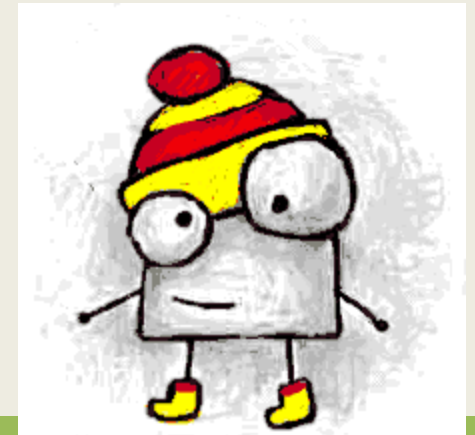

Judy and her dog run on the beach every morning.



Judy and her dog run on the beach every morning.

First find the **verb** and then make a question by placing ``who?" or ``what?" before it.

The answer is the **Judy and her dog.**

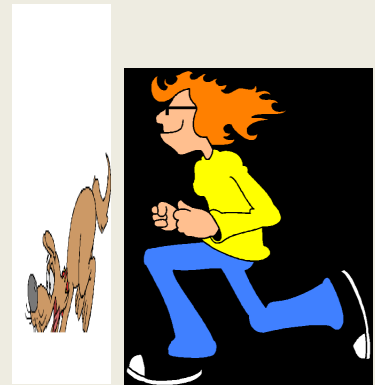



We spilled popcorn on the floor.

What is the **verb** of this sentence?

We **spilled** popcorn on the floor.



We **spilled** popcorn on the floor.

Now decide who or what spilled popcorn?

spilled popcorn on the floor.



Can you find the **subject** in each sentence below?

1. My little brother broke his finger.
2. His Uncle Bob asked for directions.
3. Those soldiers carried guns.
4. Our babysitter arrived late.

Can you find the **subject** in each sentence below?

1. **My little brother** broke his finger.
2. **His Uncle Bob** asked for directions.
3. **Those soldiers** carried guns.
4. **Our babysitter** arrived late.

Can you find the **predicate** in each sentence below?

1. My little brother broke his finger.
2. His Uncle Bob asked for directions.
3. Those soldiers carried guns.
4. Our babysitter arrived late.

Can you find the predicate in each sentence below?

1. My little brother **broke his finger.**
2. His Uncle Bob **asked for directions.**
3. Those soldiers **carried guns.**
4. Our babysitter **arrived late.**

Simple Subject and Simple Predicate

Every subject is built around one noun or pronoun (or more).

When all other words are removed the **simple subject** is left.



Simple Subject



A piece of chocolate candy
would taste great.

The main word in the **subject** is the noun "**piece**," with the other words of the subject -- "a" and "of pepperoni pizza" -- tell about the noun. "**piece**" is the simple subject.

Can you find the **simple subject** in each sentence below?

1. My little brother broke his finger.
2. His Uncle Bob asked for directions.
3. Those soldiers carried guns.
4. Our babysitter arrived late.

Can you find the **simple subject** in each sentence below?

1. My little **brother** broke his finger.
2. His **Uncle Bob** asked for directions.
3. Those **soldiers** carried guns.
4. Our **babysitter** arrived late.

Simple Predicate



A **simple predicate** is always the verb or verbs that links up with the subject.



Simple Predicate

A piece of chocolate candy
would taste great.

The simple predicate is ``would
taste'' -- in other words,
the verb of the sentence.



Can you find the **simple predicate** in each sentence below?

1. My little brother broke his finger.
2. His Uncle Bob asked for directions.
3. Those soldiers carried guns.
4. Our babysitter arrived late.

Can you find the simple predicate in each sentence below?



1. My little brother **broke** his finger.
2. His Uncle Bob **asked** for directions.
3. Those soldiers **carried** guns.
4. Our babysitter **arrived** late.

Compound Subject



A sentence may have a
-- a
simple subject made up of
more than one noun or
pronoun.

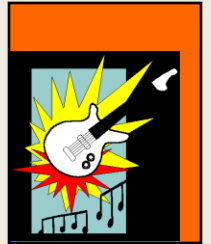

Can you find the compound subjects?

Team pennants,
rock posters and
family
photographs
covered the
boy's bedroom
walls.



Can you find the compound subjects?

Team
pennants, rock
posters and
family
photographs
covered the
boy's bedroom
walls.



Can you find the compound subjects?

Her uncle and she walked slowly through the art gallery and admired the beautiful pictures exhibited there

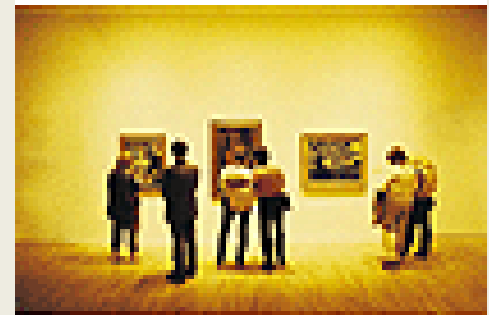

Can you find the compound subjects?



Her and walked
slowly through the art gallery
and admired the beautiful
pictures exhibited there.

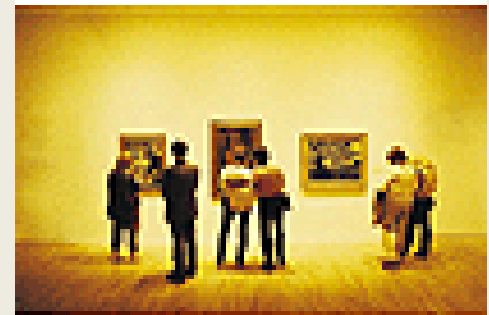

Can you find the **compound subject** in each sentence below?

1. My little brother and my cousin broke their fingers.
2. His Uncle Bob and Aunt Betty asked for directions.
3. Those soldiers and agents carried guns.
4. Our babysitter and her friend arrived late.

Can you find the **compound subject** in each sentence below?

1. My little **brother** and my **cousin** broke their fingers.
2. His **Uncle Bob** and **Aunt Betty** asked for directions.
3. Those **soldiers** and **agents** carried guns.
4. Our **babysitter** and her **friend** arrived late.

Compound Predicate



A **compound predicate**, is more than one verb relating to the same subject.



Can you find the compound predicate?

Mother mopped and scrubbed the kitchen



Can you find the compound predicate?



Mother **mopped** and **scrubbed** the kitchen floor.



Can you find the **compound predicate** in each sentence below?



1. My little brother bruised and broke his finger.
2. His Uncle Bob looked and asked for directions.
3. Those soldiers carried and used guns.
4. Our babysitter overslept and arrived late.

Can you find the **compound predicate** in each sentence below?



1. My little brother **bruised** and **broke** his finger.
2. His Uncle Bob **looked** and **asked** for directions.
3. Those soldiers **carried** and **used** guns.
4. Our babysitter **overslept** and **arrived** late.

Simple Sentences



What is a Sentence?



- A sentence is the basic unit of written communication.
- A sentence must have 3 elements:
 - A subject
 - A main verb
 - A complete thought
- To edit your writing effectively, you must have a basic understanding of what a sentence *is* and *is not*.

What is a Simple Sentence?



- A simple sentence expresses *one* complete thought.
 - I went to class.
 - She studied for two hours.
 - My English class is hard.

What is a Subject?



- A subject is the person, place, or thing that a sentence is about.
 - A subject is a noun or pronoun.
 - Some sentences may contain a compound subject, which means you could have two or more subjects (people, places, or things).

Simple Subject vs. Complete Subject

- In a sentence, the simple subject is the noun or pronoun that the sentence is about.
 - Three popular bands will perform at the concert.
- The complete subject is the noun plus the words that describe the noun.
 - Three popular bands will perform at the concert.

Identifying the subject



- Ask yourself, “Who or what is the sentence about?”
- Don’t be distracted by a prepositional phrase
 - Preposition—connects a noun, pronoun, or verb with some other info about it
 - Prepositional phrase—descriptive word group that begins with a preposition

Identifying the Subject



- The subject of the sentence is never in a prepositional phrase!
- See pg 245 in the Little, Brown Handbook for a list of prepositions.
- When looking for the subject, cross out the prepositional phrase.
 - Two **of my students** were absent today.

Identifying the Subject



- Usually, the subject is located *before* the verb in a sentence.
 - The dog chased the cat.
 - Although I was tired, I went to class.
 - My parents are paying for my classes this semester.

Identifying the Subject



- Occasionally, the subject will be found *after* or *within* the verb.
 - In some questions
 - ✦ When did she leave for school?
 - In inverted sentences that begin with *Here* or *There*.
 - ✦ Here is your textbook.
 - ✦ There are several friends coming to my graduation.

Identifying the Subject



- Also, the subject of the sentence may be unstated.
 - In a command, the unstated subject is *you*.
 - ✦ Get out of here!
 - (You) get out of here!
 - ✦ Remember to pay your tuition.
 - (You) remember to pay your tuition.

Correctly identifying the subject



- The squirrel ran up the tree to get away from the dog.
- One of my friends takes classes at A&M.
- Each of the students wants to pass the course.
- Here is my class schedule.
- Don't forget to study for the test. (You)

